

A.K. Waugh Limited

Process Heating Engineers since 1940

Immersion Heater Instructions



power generation

aggregate coating

whisky distilling

water treatment

space heating

For All Industrial Process Heating Systems

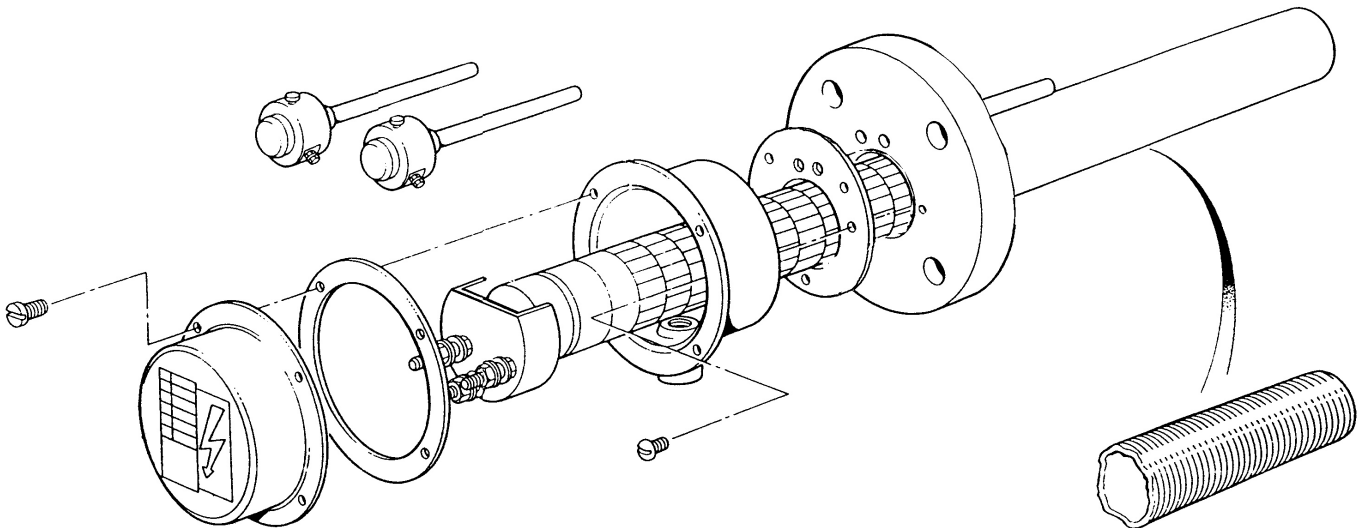

Immersion Heater variations for Fuel Oils, Water, Chemicals etc.

Find us on the Internet
At

www.processheaters.co.uk

14 Loanbank Quadrant, Govan, Glasgow G51 3HZ Scotland
tel : +44 141 440 5775 fax : +44 141 440 5702 e-mail : sales@processheaters.co.uk

Installation Instructions for Immersion Heaters with Removable Core Type Elements

1.0 Application

The Z range of immersion heaters, depending upon specification, are intended to heat water, oil and other chemical solutions and are suitable for use in building service and industrial applications. The heaters are suitable for horizontal fixing only. To avoid localised boiling or air locks, care should be taken to ensure that the cold zone extends beyond any neck piece. Refer to the supplied Heater Specification / Data Sheet for the detailed construction, specification and wiring of the heater.

2.0 Construction

The metal sheathed elements are either expanded or welded into the flange plate. The plate is sized to suit customer requirements and is generally 150mm nb PN16. A gasket is normally supplied. The terminal enclosure is either mild steel or stainless steel and is rated to IP66. Conduit entries can be drilled on site. The Z range is designed for a maximum operating pressure of 10 bar and temperature of 100°C. The heater generally conforms to BS7798.

3.0 Installation

The heater is supplied with a gasket ready to be screwed to the appropriate flange on the vessel. It is not recommended that sealing compounds are used.

Installation should ensure that the thermostats are positioned uppermost.

Heaters with immersed lengths of greater than 1200mm should be provided with internal tank support.

After fitting the heater into the vessel the system should be filled with water and a check made for leaks around the joint.

The vessel should be filled according to your standard procedure ensuring that all air pockets are purged from the system. It is important that the heating element(s) are immersed at all times during operation.

Control thermostats (if fitted) should be set to suit site requirements. The control thermostat is provided to regulate the temperature to the desired setting. When the set temperature is reached the heater circuit will switch off until the temperature falls below the differential of the thermostat. When this happens the heater circuit will energise and start the cycle again.

Recommended settings for water :

Soft Water areas : up to 82°C

Medium Hard Water areas : up to 71°C

Hard Water areas : up to 65°C

Note that scalding temperature of water is 66°C

The High Limit thermostat (if fitted) contains a manual reset cut-out. This should be set at approx. 15°C above the setting of the control thermostat. This is a safety device intended to prevent overheating. It is highly recommended that the high limit thermostat is included in all installations for safety purposes.

If any cleaning or sterilising solutions are to be "flushed" through the system prior to commissioning a check should be made to ensure that the solution will not damage the heater.

4.0 ELECTRICAL CONNECTIONS

All electrical wiring must be carried out by a competent person and must comply with current IEE regulations to BS7671. We recommend that the insulation of each circuit within the heater is checked prior to each installation. The minimum reading between live and earth should not fall below 1 MΩ. If the readings are low the element is faulty and must be replaced.

A terminal layout drawing is supplied to be used as a guide when wiring the heater.
The immersion heater must be connected to fixed wiring

The standard wiring is arranged for single or three phase supplies in either single circuit or multi stage control. It is essential that the control equipment is compatible with the heater circuit configuration and all components are correctly rated. Control equipment can be supplied by A.K. Waugh Ltd.

Thermostats must be wired through a contactor switch on all three phase supplies. A.K. Waugh Ltd. have a complete range of contactor control units suitable for this type of industrial immersion heater. Contact us for details.

Ensure all wires are labelled with the phase colour and circuit number (important for future maintenance) and cable eye connectors should be used on terminal connections.

4.0 ELECTRICAL CONNECTIONS (Contd.)

Check all electrical connections to ensure that they are tight.

After all electrical connections have been made replace the heater terminal enclosure.

Immersion heaters / circulators are designed to operate **ONLY** when the heating elements are immersed in fluid and **MUST NOT** be switched on when the heating elements are exposed to air.

The heater will only heat the contents of the tank above the immersion heater.

Should the vessel be drained at any time and the heater removed, this installation procedure must be repeated before proceeding to switch the heater circuits on.

WARNING : THIS APPLIANCE MUST BE EARTHED

5.0 MAINTENANCE

It is recommended that routine periodic checks are performed every 12 months, or every 6 months where local water supply is particularly hard or contains a high proportion of solids. All precautions must be taken against electrical shock, in particular by switching off at the mains fuse between maintenance checks. The recommended procedure is as follows :

WARNING : ALWAYS ISOLATE ELECTRICAL POWER AT THE MAINS SWITCH BEFORE REMOVING THE TERMINAL ENCLOSURE.

- 1) Isolate electrical power at the mains isolator and remove fuses.
- 2) Isolate mains cold water supply, or other fluid supply.
- 3) Visually check all joints, ensuring no leaks are evident.
- 4) Remove heater terminal cover
- 5) Disconnect incoming wiring (line connections) to busbars or element terminals as required.
- 6) Remove busbars / wire links and carry out a resistance check on the element(s) to verify continuity
- 7) Faulty element(s) must be replaced. (Refer to 7.0 below)
- 8) Check operation of thermostat(s).
- 9) We only recommend removing the heater from the vessel if the water is particularly aggressive or contains a high concentration of dissolved solids.
- 10) Drain vessel and connecting pipes according to your standard procedure before removing heater
- 11) Unbolt and completely remove the assembly from the vessel
- 12) Visually inspect element(s) for scale and corrosion. In extreme cases – and for oil applications - heavy scaling will cause increased element running temperatures and eventual element failure.
- 13) Heavily scaled or corroded elements cannot be replaced and a replacement heater may be required. Gentle application of a wire brush or similar may remove excess scale and allow continued use.
- 14) Replace any defective parts (Refer to the spare parts section)
- 15) Fit a new fibre gasket to the flange
- 16) Refer to the mechanical and electrical installation instructions section for re-fitting the heater to the vessel

6.0 SPARES ORDERING INFORMATION

It is essential when ordering spares to quote **all** the details given on the nameplate :

SERIAL NUMBER DATE KILOWATT RATING

6.1 Parts List

**Control Thermostat
High Limit Thermostat
Flange Gasket**

7.0 ELEMENT REPLACEMENT PROCEDURE

After following the maintenance procedure (5.0) above to part 7, remove any fixing screw present and withdraw the ceramic element carefully. It should be clear if the element is broken or not, evidenced usually by a breakage in the resistance wire or wires used. Occasionally the element may be in pieces and it is important that none are left within the element sheath as the presence of broken parts may impede the insertion of the new element.

Refitting is the reverse of the above procedure, taking care with the new item and not forcing it into the sheath at any time.

Cont'd.

8.0 OPERATIONAL FAULTS

Always isolate electrical power at the mains before removing the terminal cover.

LOWER THAN EXPECTED OUTPUT

- Check :
- a) Has Control Thermostat been correctly set ?
 - b) There is an element failure - check resistances
 - c) There is a fuse failure in the control unit
 - d) There is an error in the sizing of the heater

HEATER NOT OPERATING

- Check :
- a) Has the High Limit Thermostat (where fitted) tripped ?
This may be rectified by re-setting, done by depressing the button on the face of the unit.
This should only be attempted after locating and rectifying the cause of excessive temperature, which could be a fault in the control thermostat, control gear or lack of fluid in the vessel.
 - b) Main Fuses
 - c) Main Electrical Supply
 - d) Control Thermostat - may have failed in "open" position
 - e) Contactor operation and contactor coil fuse. Fault in contactor or control gear
 - f) Wiring to heater - check for loose connections
 - g) Element failure - check resistances

LOW ELEMENT INSULATION

All elements are sealed prior to despatch to prevent any ingress of water. However, storage conditions after despatch are not always ideal. In particular if there is a long delay between purchase and commissioning there may be some degree of moisture ingress into the elements. The immersion heater will not be affected by the lower insulation readings, however to allow any current control device to operate it is suggested that the following procedures be carried out.

- 1) The terminals at the end of the element can be dried to remove any moisture with a hairdryer or similar device.
- 2) When brought into operation the element will naturally improve in insulation value.
- 3) If an RCD is being used this can be disconnected while the heater is switched on to allow the insulation readings to increase.
- 4) The heater can be placed in an oven at 200-250°C for a period of time to raise the insulation levels.
NOTE - REMOVE THERMOSTATS AND ANY WIRING FIRST!
If an oven is not available then the heater can be returned to A.K. Waugh Ltd.
- 5) To maintain the insulation during periods of low use it is advisable to switch the heater on in the tank, ensuring it is covered in fluid, approximately once a month for 48 hours.

9.0 GUARANTEE

The manufacturer will make good, by repair or at his option by supply of a replacement, defects which, after proper installation has been carried out in accordance with the instructions provided above, appear in the product within a period of twelve calendar months after the goods have been delivered and arise solely from failure in design, materials or workmanship. Provided always that defective parts are promptly returned by the user free to the manufacturers works, unless otherwise arranged, the repaired parts or new parts will be delivered by the manufacturer free of charge.

Replacement or repair will not be considered if the fault is due to corrosion as this is outwith our control.

Replacement Heating Elements are available from our factory provided that full details are given, as shown on the last page. The Serial Number is vitally important.

In general, heating elements are warranted in the same way as the heater unit i.e. A one year warranty exists. However as these items are the subject of differing operating regimes the application of any warranty is at our sole discretion.

The policy of A.K. Waugh Ltd. is that of continuous improvement and development. The right is therefore reserved to change specifications without notice.