

**A.K. Waugh Limited**  
**14 Loanbank Quadrant**  
**Govan, Glasgow G51 3HZ**  
**SCOTLAND**

# **Outflow Heater Instruction Manual**

*For All Industrial Process Heating Systems*

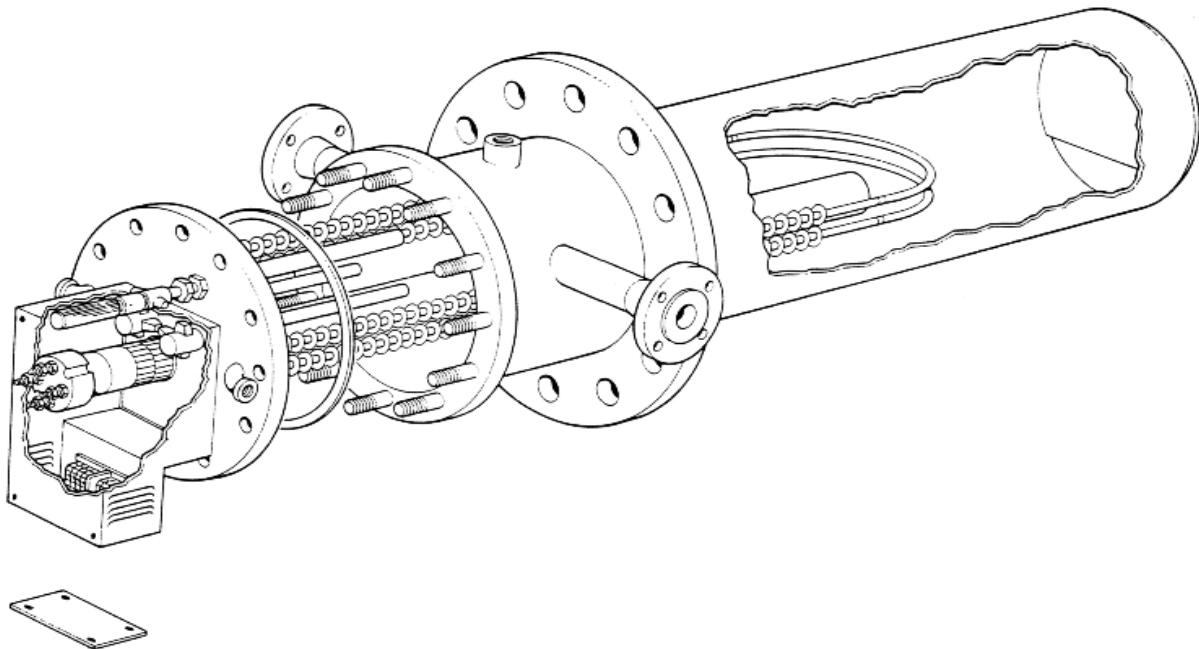

**Steam / Electric Outflow Heater for Fuel Oils, Water, Chemicals etc.**

**Find us on the Internet  
At**

**[www.processheaters.co.uk](http://www.processheaters.co.uk)**

**Tel : +44 141 440 5775**  
**Fax : \_44 141 440 5702**  
**Email : sales@akwaugh.com**

**A.K. Waugh Limited**  
**14 Loanbank Quadrant**  
**Govan, Glasgow G51 3HZ**  
**SCOTLAND**

**Contents**

- 1.0**            **Installation**
- 2.0**            **Electrical Connections**
- 3.0**            **Steam or Hot Water Connections**
- 4.0**            **Standard Accessories**
- 5.0**            **Methods of Operation of Heater Unit**
- 6.0**            **Setting of Thermostats**
  - 6.1**            **General Information**
  - 6.2**            **Control Thermostats**
  - 6.3**            **Master Thermostat**
  - 6.4**            **Steam thermostatic Valves**
- 7.0**            **Maintenance**
  - 7.1**            **Periodic**
  - 7.2**            **General Overhaul**
- 8.0**            **Spares**
  - 8.1**            **Thermostats**
  - 8.2**            **Heating Elements**
  - 8.3**            **Steam Thermostat**
  - 8.4**            **Steam Valve**
- 9.0**            **Fault Correction**
  - 9.1**            **Poor Control Characteristics**
  - 9.2**            **Required Outlet Temp. Unobtainable**
  - 9.3**            **Constant Fuse Failure**
  - 9.4**            **Master Thermostat Trips Out**
- 10.0**           **Spares Ordering Information**

**A.K. Waugh Limited**  
**14 Loanbank Quadrant**  
**Govan, Glasgow G51 3HZ**  
**SCOTLAND**

***Installation Instructions***

***For***  
***Steam / Hot Water***  
***and***  
***Electric Outflow Heaters***

**1.0 Installation**

The standard range of Steam / Electric Heaters are only suitable for horizontal mounting. If vertical mounting is required a special version of the heater is required.

The oil outlet connection is normally located on the left or right hand side of the heater body (when viewed from the terminal box). This connection is screwed BSP or flanged. When an oil return is specified this is normally located on the opposite side of the body tube. A drain connection is provided when requested.

Adequate withdrawal space must be provided for both horizontal and vertically mounted heaters to enable the heating element cores and heating battery removal.

The withdrawal distance is given on the drawing supplied.

The bolt-to-tank models are supplied with an oil joint.

**2.0 Electrical Connections**

Conduit bosses or a detachable plate for drilling on site are provided at the base of the terminal box, although adequate space can normally be found on the enclosure for the Plant Engineer to add additional conduit connections if required.

Since all thermostats are of single phase connection and of 15 amp A.C. maximum rating, direct connection to the electrical supply is limited to 3.0 kW single phase 220/250 volts A. C. Current loads in excess of 15 amp A.C. and all three phase and D.C. supplies necessitate the use of a separate contactor for each electrical heating stage.

The coil circuit of the contactor is normally wired in series with the master thermostat / control thermostat, and when specified a hand operated switch. It is important that for multi-stage heaters, the control thermostats are connected to the coil of the corresponding contactor, as shown on the wiring diagram.

**3.0 Steam or Hot Water Connections**

Two connections are provided, one for supply and the other for condense or return. The steam supply connection is generally located slightly higher on the tube plate than the condense connection, although the choice is ultimately a matter of convenience.

A pocket is provided in the tube plate for a Sarco steam thermostat. If this is not required there will be a 1" BSP connection available for whatever control device is specified. The steam valve, where supplied, is fitted (on-site) local to the steam supply connection. Working instruction cards are provided in the case containing the valve and thermostat. (See section for details of valves). When ordered, a trapping set can be supplied comprising :

Strainer, Steam Trap, Sight Glass and Isolating Valves as appropriate.

**A.K. Waugh Limited**  
**14 Loanbank Quadrant**  
**Govan, Glasgow G51 3HZ**  
**SCOTLAND**

#### **4.0 Standard accessories**

All accessories, except thermostats, are supplied as loose items. These items normally comprise the oil joint and thermometer. When supplied the thermometer is provided with a 1/2" BSP mild steel pocket so that the instrument can be removed without draining off the liquid in the heater body / tank.

#### **5.0 Methods of Operation of Heater Unit**

Heat is transferred to the liquid by means of :

- a) Removable ceramic formed electric heating elements (cores).
- b) Steam coil or 'U' Tubes.

The electric elements are fitted into a mild steel or stainless steel sheath (tube). Control and master (safety cut-out) thermostats are standard features to the heating battery and thus automatic control can be achieved. Unless otherwise requested, in multi-tube units, the minimum number of heating elements to each control thermostat is three. All thermostat switches are the normally closed type ("ON") so that an increase in liquid temperature above the adjustable set temperature of the thermostat, opens the heater circuit ("OFF").

The steam coil can be either a continuous coiled tube or a 'U' tube arrangement. The thermostatic steam regulator is a two part unit comprising valve and thermostat. The valve is controlled via a capillary tube by the thermostat which is fitted to the pocket provided. The valve is a fully modulating hydraulically operated pattern incorporating packless glands.

#### **6.0 Setting of Thermostats**

##### **6.1 General Information**

Thermostats fitted have adjustable scales covering the temperature control range required. Each thermostat is fitted in a pocket which enables replacement without draining down the vessel contents.

It has been experimentally justified that for this type of control system locating the thermostats in this position does reduce the oil outlet temperature differential to more reasonable limits. This differential is usually due to the large ratio between the heat content of the element and normal flow rates through the heater.

If more than one thermostat is fitted, each control thermostat is mounted directly above a heating core which is within that particular control group.

In most cases the control thermostat(s) sense a higher temperature than the actual liquid temperature since it is in the direct path of the hot liquid rising by convection from the heater element sheaths.

**A.K. Waugh Limited**  
**14 Loanbank Quadrant**  
**Govan, Glasgow G51 3HZ**  
**SCOTLAND**

### **6.2 Control Thermostats**

If only one control thermostat is fitted to the heater unit it will be necessary, depending on application / design, to set this 10 to 15 degrees centigrade above the desired liquid outlet temperature.

This adjustment which offsets the internal liquid temperature as sensed by the probe, varies according to the flow rate and local liquid viscosity.

Where more than one control thermostat is fitted they should be set at different temperatures so that a base load is "ON" much longer than the makeup load which is operating ON/OFF.

If three thermostats are incorporated, the same principal applies to obtain a base load, intermediate load and makeup load.

The above remarks concerning the thermostats are only intended as a guide.

If the flow rate is low and the temperature rise is large, control is more difficult to achieve than when the flow rate is high and the temperature rise is small.

### **6.3 Master Thermostat**

One master thermostat is supplied with each heater to protect the unit from excessive liquid temperature when a fault arises. The thermostat is usually set 25 degrees C above the liquid outlet temperature or any other temperature that may be recommended.

When this temperature is exceeded the master thermostat opens all the heater circuits thus closing down the system.

In some cases, the master thermostat is wired in series with the liquid transfer pump electrical system. As a matter of good practice, this should incorporate a system whereby the pump continues to operate for a short period of time (say five minutes) to ensure that the liquid in the heater does not overheat due to residual heat build up within the heater, although this is not a particular problem with A.K. Waugh Ltd. heaters.

It is necessary to manually reset the thermostat since it will not automatically close as the temperature falls.

N.B. It is very important that the mains supply is isolated before attempting to reset the master thermostat since the operator may be unaware of energising the heater elements as soon as the thermostat is reset. Suitable precautions should be taken, such as highlighted signage.

### **6.4 Steam Thermostatic Valves**

The steam valve should always be fitted in a horizontal pipeline with the valve closing element vertically below the line.

Contd..

**A.K. Waugh Limited**  
**14 Loanbank Quadrant**  
**Govan, Glasgow G51 3HZ**  
**SCOTLAND**

#### **6.4 Steam Thermostatic Valves**

It is important the line stresses such as can be caused by expansion or inadequate pipe supports are not exposed on the valve body. If the valve has been correctly sized for the duty it has to perform it will often be smaller than the pipeline to and from it. Reduction in pipeline dimensions to be made by eccentric reducers.

It is advisable to protect the valve by fitting a strainer on the upstream side.

The thermostat should be set on site to the required temperature.

Please read instructions on the cards attached to the valve and thermostat.

The temperature settings of both steam and electric thermostats are to be as close to one another as possible. DO NOT set the electric thermostats higher than the steam instrument as this results in damage to the valve seat in the valve, and can result in the need for a complete new valve.

#### **7.0 Maintenance**

##### **7.1 Periodic**

- a) Ensure that all electrical connections remain clean, tight and dry.
- b) Check for liquid leakage around bolt-to-tank joint and element sheaths.
- c) When a drain connection is provided loosen drain valve and check for sludge build-up. If this is excessive, isolate heater and drain off quantity of sludge.

##### **7.2 General Overhaul**

- a) Isolate heater electrically
- b) Remove terminal box lid.
- c) Disconnect incoming cables from terminal block and release conduit connections.
- d) Drain tank / vessel contents.
- e) Remove heater battery from shell unit and inspect sheaths and shell for scale and corrosion. Remove scale by wire brushing.
- f) Examine electrical connections for soundness. There is no need to remove heating elements unless an electrical fault has been reported.
- g) Replace element battery using a new gasket.
- h) Fill tank and re-fit as reverse of (d), (c) and (b).

**A.K. Waugh Limited**  
**14 Loanbank Quadrant**  
**Govan, Glasgow G51 3HZ**  
**SCOTLAND**

**8.0 Spares**

**8.1 Thermostats**

If a thermostat is faulty in any way it must be returned to our works for inspection. Thermostats can be easily removed by releasing the electrical connections and pinching screws.

Standard thermostats are available from stock, but others may be several weeks delivery.

When a spare thermostat is required give full details of heater unit off of the name plate.

**8.2 Heating Elements**

Replacement heating elements can be promptly obtained from our works provided the full details of the equipment including voltage and loading are given.

Heating elements are easily removed and fitted by loosening the retaining clip screws.

If elements are initially difficult to remove covered grips can be applied to the terminal pin, but this is rarely necessary unless access is difficult.

IMPORTANT NOTE !

IF CORES ARE SO DIFFICULT TO REMOVE THAT SEVERE DAMAGE RESULTS THEN CONTACT US IMMEDIATELY. YOU MAY NEED A COMPLETELY NEW TUBE PLATE ASSEMBLY.

**8.3 Steam Thermostat**

The thermostat is a sealed unit. If it is damaged, or a spare is required, please return it to our factory, or order the required part by quoting the serial number of both the valve and the heater.

**8.4 Steam Valve**

Please order by quoting the serial number of both the valve and the heater.

**A.K. Waugh Limited**  
**14 Loanbank Quadrant**  
**Govan, Glasgow G51 3HZ**  
**SCOTLAND**

**9.0 Fault Correction**

**9.1. Poor Control Characteristics**

a) Ensure that flow and temperature conditions are the same as those for which the heater was manufactured. If not please contact us immediately for assistance.

a) Reset thermostat in accordance with section 4.

Control differentials do not usually exceed +5 degrees C and in most applications +3 degrees C is obtained.

b) Check steam supply pressure, also valve and thermostat positioning is correct. Check with our factory that the valve size is adequate and the scale on the thermostat is correct.

**9.2. Required Outlet Temperature Unobtainable**

This can be due to the failure of one or more heating elements, incorrect thermostat setting (steam or electric) or failure of the steam heating system. If the fault is identified as being in the heater, please refer to our factory quoting the serial number of the heater. All possible assistance will be given to solve the problem.

**9.3. Constant Fuse Failure**

Check earth insulation and phase / phase insulation of heater unit.

Resistance readings should be better than 1 ohm. when cold. However, if the heater has been in a damp environment for some time, it is possible that the ceramic heating cores are also damp, thus giving poor insulation valves.

Rectify by drying cores in a warm oven or by carefully applying a low voltage supply to the elements.

**9.4. Master Thermostat Trips Out**

Before manually resetting the master thermostat carefully check cause of trip.

The cause could be :-

a) Master thermostat setting is too low and responds to temperature build up when heater is shut down. Set thermostat at least 25 degrees C above storage temperature.

b) Failure of control thermostat to open circuit (OFF) on rise in liquid temperature.

Contd..

**A.K. Waugh Limited**  
**14 Loanbank Quadrant**  
**Govan, Glasgow G51 3HZ**  
**SCOTLAND**

**10.0 Spares Ordering Information**

IT IS ESSENTIAL when ordering spares to quote all the details as given on the nameplate comprising:-

**SERIAL NUMBER**

**KILOWATT RATING**

**VOLTAGE**

We would emphasise that spares enquiries for our equipment which do not include the above details may be subject to delay due to our having to search our records for the correct information.

For a speedy response we would appreciate a telephone call, at which time we will be able to advise the potential manufacturing time required etc.

If you wish to simply replenish your spares holding, a fax or email enquiry will suffice and will be dealt with by return fax or email where possible. Please give the clearest details on your fax or email

Please check our website, [www.akwaugh.com](http://www.akwaugh.com) or [www.processheaters.co.uk](http://www.processheaters.co.uk) for contact information. Our email address is :

**[sales@akwaugh.com](mailto:sales@akwaugh.com)**  
**or**  
**[sales@processheaters.co.uk](mailto:sales@processheaters.co.uk)**